



HAWK

Reach Beyond, with HAWK.

VISIT SITE NOW »

Long Reach Stick and Boom

LRA6075

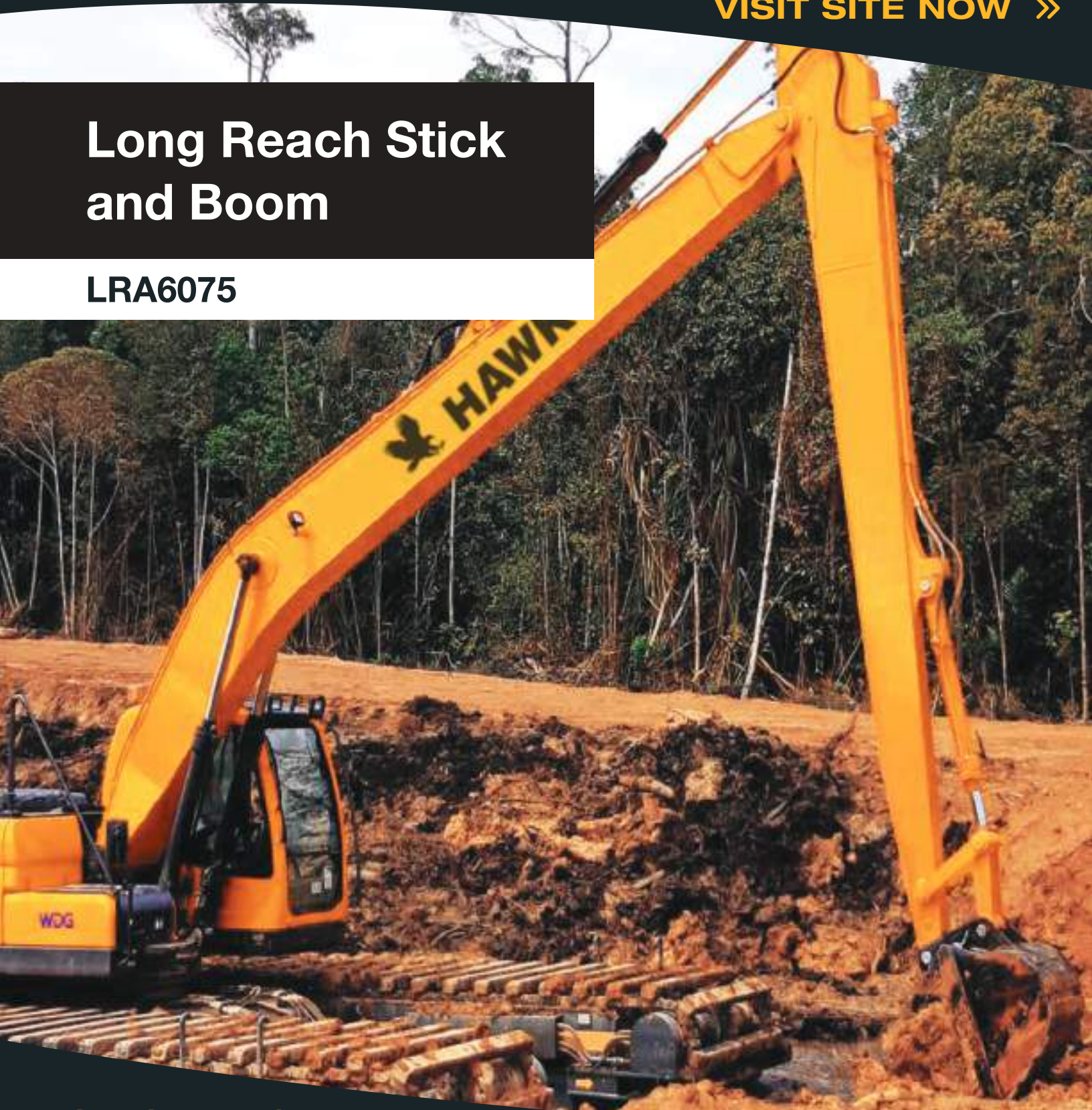

VISIT SITE NOW »

www.hawkexcavator.com

| (619) 335-8822

| info@hawkexcavator.com



HAWK

Reach Beyond, with HAWK.

VISIT SITE NOW »



HAWK

HAWK Excavator, under the brand “HAWK” is an American company selling versatile, high-quality Long Reach Systems that fit various brands of excavators. HAWK is well known in the excavator industry due to the organization’s reliability and capacity to supply high-quality and reasonably priced products.

Our production facility is ISO 9001, certified in 2011. HAWK can guarantee consistent quality manufacturing and timely delivery of our long reach systems, and other excavator products. Along with our ISO 9001 certification, HAWK is also CE certified; each HAWK Long Reach System bears the CE logo.

Each and every HAWK Long Reach System is manufactured to comply with our quality system to ensure that our customers always receive the high-quality product that they require.

ISO 9001



VISIT SITE NOW »

www.hawkexcavator.com

| (619) 335-8822

| info@hawkexcavator.com



HAWK

Reach Beyond, with HAWK.

VISIT SITE NOW »



VISIT SITE NOW »

www.hawkexcavator.com

| (619) 335-8822

| info@hawkexcavator.com



OPERATING RANGES

Each Long Reach Arm comes with the following items

- 1 Boom x1 unit
- 2 Arm x1 unit
- 3 High-quality hydraulic bucket cylinder x1 unit
- 4 Hydraulic tubing with clamp x1 set
- 5 Hydraulic pressure hose x1 set
- 6 Bucket linkage c/w 2 pins x1 set
- 7 Bucket pin x2 pcs
- 8 Arm cylinder pin x1 pcs
- 9 Yoke pin x1 pcs
- 10 EM bushings
- 11 CE bucket c/w teeth x1 unit
- 12 Seal kit, hydraulic bucket cylinder x1 set

Pre-Plumbed Hydraulic Lines and Hose Brackets optional

- Pre-Plumbed saves time and gets the project started sooner.
- 3 guys/8hr day doing setup equals 24 hours of labor time that can be avoided by using HAWK long arms that are ready on arrival. (Hydraulics and Hose Brackets Installed)
- Supports both hydraulic dredge pump attachments or standard mechanical dredging.

*Pump not included.

LONG REACH / BOOM

*Extension, not bucket compatibe

EXTENDED REACH PRE-PLUMBED HYDRAULICS



Bucket



Pump



Pump + Arm Extension



[VISIT SITE NOW >>](#)

OPERATING WEIGHTS and DIMENSIONS

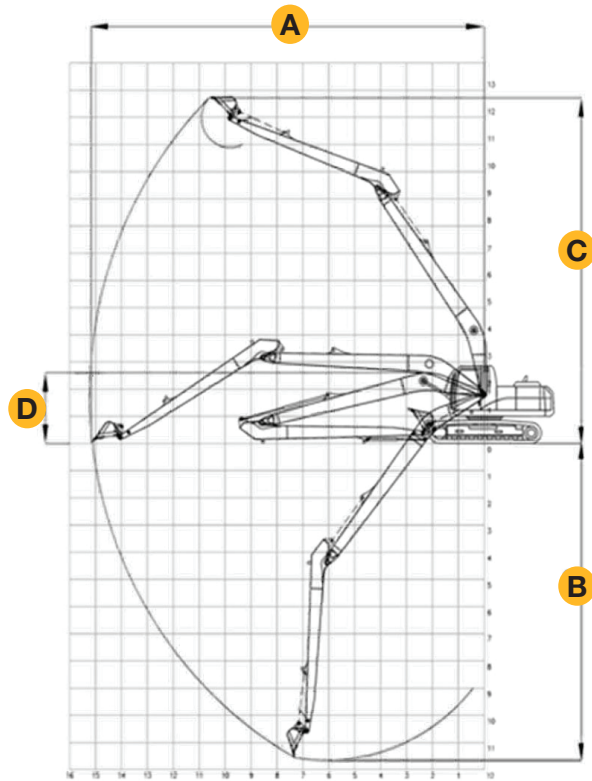

Model - LRA6075

Excavator Operating Weight (ton)	60-65
Length	75.6 ft (23 m)
Boom Length	42.6 ft (12.9 m)
Arm Length	32.9 ft (10 m)
Max Reach (A)	75.8 ft (23.1 m)
Max Depth (B)	58.2 ft (17.7 m)
Max Height (C)	68.5 ft (20.9 m)
Boom Height (D)	12.1 ft (4 m)
Bucket Capacity	1.6 yd ³ (1.2 m ³)

Analysis and Simulation

Simulation Stress and Strength Analysis is conducted on every long reach arm produced to ensure quality and durability required. Our analysis is performed by trained engineers with the newest application CAD software.

NDT Test

HAWK’s superior quality welding is key to the strength and durability of our Long Reach Arm. NDT testing is conducted to ensure all welds meet or exceed our quality standard. Our customers can rest assured knowing that every HAWK Long Arm will provide long-lasting performance they can count on.

[VISIT SITE NOW >>](#)



HAWK

Reach Beyond, with HAWK.

VISIT SITE NOW >>

OEM PRODUCTS

- * Long Arm
- * Amphibious Undercarriage
- * RTK GPS System

-  **1 BUCKET**
-  **2 LONG ARM**
-  **3 HYDRAULIC CYLINDER**
-  **4 BOOM**
-  **5 AMPHIBIOUS UNDERCARRIAGE (TRACKS)**



EXCAVATOR COMPONENTS



VISIT SITE NOW >>



HAWK

Reach Beyond, with HAWK.

VISIT SITE NOW »

LONG REACH FEATURES



Long-Reach Arm includes

Boom, arm, linkage, bucket, cylinders (boom, arm, and bucket), hydraulic lines, and additional counterweight (optional) for added stability.

Design Concept

Designed specifically for river, swamp, lake, canal, and many other wetland environments.

Extending Working Reach

HAWK's Long Reach System extends the working reach of your excavator to increase efficiency and enable greater productivity, while at the same time providing greater stability and smooth operation of your excavator.

Rugged Front Attachment

The heavy-duty front attachment is built using high-tensile strength (S355JR) extra thick steel plates that provide greater durability than most of the Long Reach Arms available.

Low Folding Profile for Easy Transportation

The long reach arm can be folded to a low profile for the convenience of easy transportation to-and-from the job site.

VISIT SITE NOW »

www.hawkexcavator.com

| (619) 335-8822

| info@hawkexcavator.com



HAWK

Reach Beyond, with HAWK.

VISIT SITE NOW >>

BOOM and ARM

- Reinforced arm and boom to withstand high-impact.
- Reinforced plates to provide greater protection. The arm center and end sections have been strengthened.

RUGGED FRONT ATTACHMENT

The heavy-duty front attachment is built using high tensile strength (S355JR) extra thick steel plates that provide greater durability than most of the Long Reach Arms available.

EM BUSHING

- Pocket and dimple surface pattern traps grease to optimize lubrication.
- Wear resistant solid lubricant coating provides noise free and enhances anti-seizure property.
- 30% longer life compared to normal steel bush surface pattern.



ADVANCED GP BUCKET

- HAWK's new GP bucket designed for higher productivity.
- Newly designed side cutter and abrasion resistant steel increases bucket solidity.



VISIT SITE NOW >>



HAWK

Reach Beyond, with HAWK.

VISIT SITE NOW »

PRE-PLUMBED HYDRAULIC and HOSE CONNECTIONS

- Hydraulics are plug-n-play, attach your tool and work.
- Optional Slurry Discharge Hose Brackets for Dredge Pumps.



VISIT SITE NOW »