



HAWK

Reach Beyond, with HAWK.

VISIT SITE NOW »

PRODUCTION-CLASS EXCAVATORS

ZX470LC-6



ZAXIS

DASH 6

VISIT SITE NOW »



HAWK

Reach Beyond, with HAWK.

[VISIT SITE NOW >>](#)

ZX470LC-6

PROVEN PERFORMANCE PASSED DOWN.

PRODUCTIVITY-BOOSTING ADVANTAGES.

At Hitachi, efficiency, reliability and durability are in our genes – built into our large mining excavators and passed down to our line of construction excavators. So you get maximum performance, no matter which Hitachi excavator you're running. And our production-class excavators, like the ZX470LC-6, prove it.

The ZX470LC-6 is purpose-built with productivity-boosting advantages. This workhorse features a fuel-efficient EPA Final Tier 4 (FT4)/EU Stage IV Isuzu engine that meets rigid emission standards – no diesel particulate filter needed. Generous swing torque, digging force and lift capacity. Standard upperstructure handrails for added safety and accessibility. Easy-to-operate controls for smooth and responsive hydraulics. Highly efficient cooling system. And simplified maintenance with features like a battery disconnect switch and engine and hydraulic oil sample ports. Add it all up, and the ZX470LC-6 gives you...

A COMPETITIVE EDGE.



[VISIT SITE NOW >>](#)



HAWK

Reach Beyond, with HAWK.

VISIT SITE NOW »



PERFORMANCE

VISIT SITE NOW »



HAWK

Reach Beyond, with HAWK.

VISIT SITE NOW »

PRODUCTIVITY



VISIT SITE NOW »

www.hawkexcavator.com | (713) 230 8725 | info@hawkexcavator.com



HAWK

Reach Beyond, with HAWK.

[VISIT SITE NOW >>](#)

READY TO TACKLE YOUR TOUGHEST JOBS.

PRODUCTIVITY ON A HIGHER LEVEL.

The ZX470LC-6 takes productivity to a higher level. Our HIOS III hydraulic system perfectly balances engine performance with hydraulic flow. The hydraulic boost system and enhanced boom recirculation generate aggressive boom and arm speed – returning the arm to dig faster, so you can move more dirt in a day.

The ZX470LC-6 provides efficient power with three work modes to fit the task. High Productivity (H/P) delivers more power and faster hydraulic response. Power (PWR) delivers a balance of power and speed, plus fuel economy for normal operation. Economy (ECO) maximizes fuel efficiency while delivering an enhanced level of productivity.

Need extra stability or lift capacity? Choose from a wide variety of track widths, arm lengths, boom lengths and bucket sizes.

With the ZX470LC-6, you get...

MORE DONE, MORE EFFICIENTLY.

- It's not always about brute force. Unmatched metering and smooth multifunction operation provide finesse and precision.

- Stay on schedule with generous swing torque, digging force and lift capacity.

- Muscle through tough digging by pressing the power-boost button.

- An added coolant expansion tank provides make-up fluid when needed and improves cooling system efficiency, keeping the engine at peak performance.

[VISIT SITE NOW >>](#)



[VISIT SITE NOW >>](#)

ZX470LC-6

Engine	ZX470LC-6		
Manufacturer and Model	Isuzu GU2I		
Non-Road Emission Standards	EPA Final Tier 4 / EU Stage IV		
Net Rated Power (ISO 9249)	270 kW (362 hp) @ 2,000 rpm		
Cylinders	6		
Displacement	9.84 L (600 cu. in.)		
Off-Level Capacity	70% (35 deg.)		
Aspiration	Turbocharged, air-to-air charge-air cooler		
Cooling			
Cool-on-demand, hydraulic-driven, suction-type fan with remote-mounted drive			
Powertrain			
2-speed propel with AutoShift			
Maximum Travel Speed			
Low	3.9 km/h (2.4 mph)		
High	5.5 km/h (3.4 mph)		
Drawbar Pull	33 537 kg (73,937 lb.)		
Hydraulics			
Open center, load sensing			
Main Pumps	2 variable-displacement pumps		
Maximum Rated Flow	400 L/m (106 gpm) x 2		
System Operating Pressure			
Circuits			
Implement	31 900 kPa (4,627 psi)		
Travel	35 300 kPa (5,120 psi)		
Swing	28 400 kPa (4,119 psi)		
Power Boost	35 300 kPa (5,120 psi)		
Controls	Pilot levers, short-stroke, low-effort hydraulic pilot controls with shutoff lever		
Cylinders			
Heat treated, chrome-plated, polished cylinder rods, hardened steel (replaceable bushings) pivot pins			
	Bore	Rod Diameter	Stroke
Boom (2)	170 mm (6.7 in.)	115 mm (4.5 in.)	1590 mm (62.6 in.)
Arm (1)	190 mm (7.5 in.)	130 mm (5.1 in.)	1940 mm (76.4 in.)
Bucket (1)	170 mm (6.7 in.)	120 mm (4.7 in.)	1325 mm (52.2 in.)
Electrical			
Number of Batteries (12 volt)	2		
Battery Capacity	500 CCA		
Alternator Rating	100 amp		
Work Lights	5 halogen (1 mounted on frame, 2 mounted on boom, and 2 mounted on top of cab)		
Undercarriage			
Rollers (each side)			
Carrier	3		
Track	9		
Shoes, Triple Semi-Grousers (each side)	53		
Track			
Adjustment	Hydraulic		
Guides	Front and center		
Chain	Sealed and lubricated		
Planetary Final Drives with Axial Piston Motors			

[VISIT SITE NOW >>](#)



HAWK

Reach Beyond, with HAWK.

VISIT SITE NOW >>

Ground Pressure		ZX470LC-6
750-mm (30 in.) Triple Semi-Grouser Shoes		72.1 kPa (10.5 psi)
900-mm (36 in.) Triple Semi-Grouser Shoes		60.1 kPa (8.7 psi)
Swing Mechanism		
Swing Speed		9.5 rpm
Swing Torque		148 000 Nm (109,159 lb.-ft.)
Serviceability		
Refill Capacities		
Fuel Tank		675 L (178 gal.)
Diesel Exhaust Fluid (DEF) Tank		95 L (25.1 gal.)
Cooling System		62.3 L (16.5 gal.)
Engine Oil with Filter		41 L (11 gal.)
Hydraulic Tank		310 L (82 gal.)
Hydraulic System		510 L (135 gal.)
Gearbox		
Swing (each)		6.5 L (6.9 qt.)
Travel (each)		11 L (11.6 qt.)
Operating Weights		
With full fuel tank; 79-kg (175 lb.) operator; 2.34-m ³ (3.06 cu. yd.), 1370-mm (54 in.), 2031-kg (4,478 lb.) bucket; 3.9-m (12 ft. 10 in.) arm; 8400-kg (18,519 lb.) counterweight with removal device; and 900-mm (36 in.) triple semi-grouser shoes		
SAE Operating Weight		50 260 kg (110,804 lb.)
Optional Components		
Undercarriage w/ Triple Semi-Grouser Shoes		
750 mm (30 in.)		18 298 kg (40,340 lb.)
900 mm (36 in.)		18 978 kg (41,839 lb.)
One-Piece Boom (w/ arm cylinder)		
7-m (23 ft.)		4499 kg (9,919 lb.)
Mass Excavating Boom		
6.3-m (20 ft. 7 in.)		4544 kg (10,018 lb.)
Arm with Bucket Cylinder and Linkage		
2.9 m (9 ft. 6 in.)		2534 kg (5,587 lb.)
3.4 m (11 ft. 2 in.)		2539 kg (5,598 lb.)
3.9 m (12 ft. 10 in.)		2640 kg (5,820 lb.)
4.9 m (16 ft. 1 in.)		2320 kg (5,115 lb.)
Boom-Lift Cylinders (2), Total Weight		840 kg (1,853 lb.)

VISIT SITE NOW >>



VISIT SITE NOW >>

Operating Dimensions		ZX470LC-6				
Arm Length	2.9 m (9 ft. 6 in.)	2.9 m (9 ft. 6 in.)	3.4 m (11 ft. 2 in.)	3.9 m (12 ft. 10 in.)	4.9 m (16 ft. 1 in.)	
		w/ 6.3-m (20 ft. 7 in.) Mass-Excavating Boom				
Arm Digging Force						
SAE	252 kN (56,652 lb.)	249 kN (55,977 lb.)	215 kN (48,334 lb.)	196 kN (44,063 lb.)	175 kN (39,342 lb.)	
ISO	259 kN (58,226 lb.)	256 kN (57,551 lb.)	222 kN (49,908 lb.)	201 kN (45,187 lb.)	177 kN (39,791 lb.)	
Bucket Digging Force						
SAE	254 kN (57,101 lb.)	257 kN (57,776 lb.)	256 kN (57,551 lb.)	256 kN (57,551 lb.)	213 kN (47,884 lb.)	
ISO	285 kN (64,071 lb.)	285 kN (64,071 lb.)	286 kN (64,295 lb.)	286 kN (64,295 lb.)	238 kN (53,505 lb.)	
A Maximum Reach	11.40 m (37 ft. 5 in.)	10.86 m (35 ft. 8 in.)	12.06 m (39 ft. 7 in.)	12.49 m (41 ft.)	13.34 m (43 ft. 9 in.)	
A' Maximum Reach at Ground Level	11.17 m (36 ft. 8 in.)	10.61 m (34 ft. 10 in.)	11.84 m (38 ft. 10 in.)	12.28 m (40 ft. 3 in.)	13.14 m (43 ft. 1 in.)	
B Maximum Digging Depth	7.28 m (23 ft. 11 in.)	6.23 m (20 ft. 5 in.)	7.77 m (25 ft. 6 in.)	8.27 m (27 ft. 2 in.)	9.11 m (29 ft. 11 in.)	
B' Maximum Digging Depth at 2.44-m (8 ft.) Flat Bottom	7.08 m (23 ft. 3 in.)	6.08 m (19 ft. 11 in.)	7.63 m (25 ft.)	8.14 m (26 ft. 8 in.)	9.0 m (29 ft. 6 in.)	
C Maximum Cutting Height	10.25 m (33 ft. 8 in.)	10.88 m (35 ft. 8 in.)	11.06 m (36 ft. 3 in.)	11.16 m (36 ft. 7 in.)	11.73 m (38 ft. 6 in.)	
D Maximum Dumping Height	7.03 m (23 ft. 1 in.)	7.33 m (24 ft. 1 in.)	7.65 m (25 ft. 1 in.)	7.77 m (25 ft. 6 in.)	8.67 m (28 ft. 5 in.)	
E Minimum Swing Radius	5.02 m (16 ft. 6 in.)	3.93 m (12 ft. 11 in.)	4.84 m (15 ft. 11 in.)	4.81 m (15 ft. 9 in.)	4.85 m (15 ft. 11 in.)	
F Maximum Vertical Wall	5.27 m (17 ft. 3 in.)	5.02 m (16 ft. 6 in.)	6.59 m (21 ft. 7 in.)	6.98 m (22 ft. 11 in.)	8.42 m (27 ft. 7 in.)	
G Tail Swing Radius	3.67 m (12 ft.)	3.67 m (12 ft.)	3.67 m (12 ft.)	3.67 m (12 ft.)	3.67 m (12 ft.)	

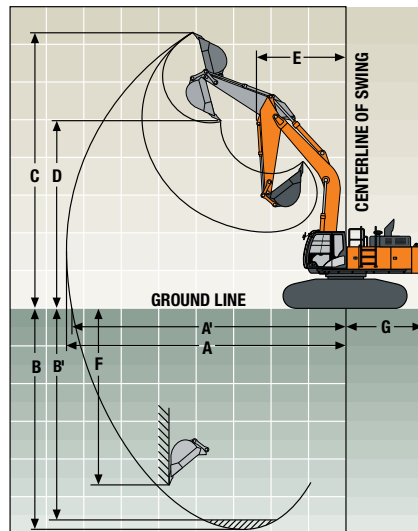

VISIT SITE NOW >>



HAWK

Reach Beyond, with HAWK.

VISIT SITE NOW >>

Machine Dimensions	ZX470LC-6	
A Overall Length w/ Arm		
2.9 m (9 ft. 6 in.)	12.10 m (39 ft. 8 in.)	
3.4 m (11 ft. 2 in.)	12.01 m (39 ft. 5 in.)	
3.9 m (12 ft. 10 in.)	12.01 m (39 ft. 5 in.)	
4.9 m (16 ft. 1 in.)	12.0 m (39 ft. 4 in.)	
2.9 m (9 ft. 6 in.) with 6.3-m (20 ft. 7 in.) Boom	11.32 m (37 ft. 2 in.)	
B Overall Height w/ Arm		
2.9 m (9 ft. 6 in.)	3.60 m (11 ft. 10 in.)	
3.4 m (11 ft. 2 in.)	3.48 m (11 ft. 5 in.)	
3.9 m (12 ft. 10 in.)	3.50 m (11 ft. 6 in.)	
4.9 m (16 ft. 1 in.)	4.55 m (14 ft. 11 in.)	
2.9 m (9 ft. 6 in.) with 6.3-m (20 ft. 7 in.) Boom	3.74 m (12 ft. 3 in.)	
C Rear-End Length/Swing Radius	3.67 m (12 ft.)	
D Distance Between Idler/Sprocket Centerline	4.47 m (14 ft. 8 in.)	
E Undercarriage Length	5.47 m (17 ft. 11 in.)	
F Counterweight Clearance	1.36 m (4 ft. 6 in.)	
G Upperstructure Width	3.48 m (11 ft. 5 in.)	
H Cab Height	3.33 m (10 ft. 11 in.)	
I Track Width w/ Triple Semi-Grouser Shoes	750 mm (30 in.) / 900 mm (36 in.)	
J Gauge Width		
Operating Position	2.89 m (9 ft. 6 in.)	
Transport Position	2.39 m (7 ft. 10 in.)	
K Ground Clearance	0.74 m (29 in.)	
L Overall Width w/ Triple Semi-Grouser Shoes		
750 mm (30 in.)		
Operating Position	3.64 m (11 ft. 11 in.)	
Transport Position	3.14 m (10 ft. 4 in.)	
900 mm (36 in.)		
Operating Position	3.79 m (12 ft. 5 in.)	
Transport Position	3.29 m (10 ft. 10 in.)	

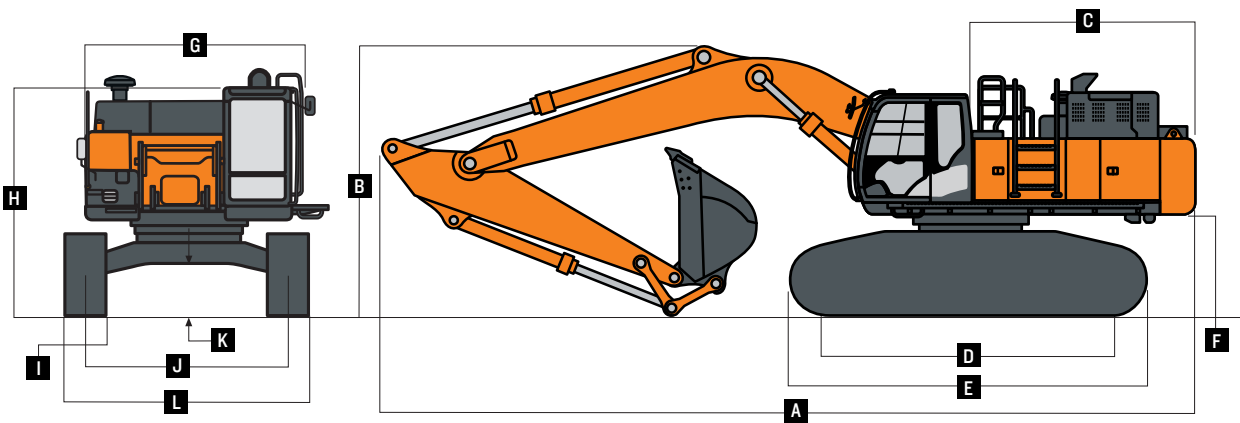

VISIT SITE NOW >>



HAWK

Reach Beyond, with HAWK.

VISIT SITE NOW >>

Lift Charts ZX470LC-6

Boldface type indicates hydraulically limited capacity; **lightface type** indicates stability-limited capacities, in kg (lb.). All lift capacities are based on ISO 10567 (with power boost). Machine equipped with standard gauge; and situated on firm, uniform supporting surface. Total load includes weight of cables, hook, etc. Figures do not exceed 87 percent of hydraulic capacities or 75 percent of weight needed to tip machine.

Load Point Height	1.5 m (5 ft.)		3.0 m (10 ft.)		4.5 m (15 ft.)		6.0 m (20 ft.)		7.5 m (25 ft.)		9.0 m (30 ft.)		10.5 m (35 ft.)	
Horizontal Distance from Centerline of Rotation	Over Front	Over Side	Over Front	Over Side	Over Front	Over Side	Over Front	Over Side	Over Front	Over Side	Over Front	Over Side	Over Front	Over Side
With 3.9-m (12 ft. 10 in.) arm, 7.0-m (23 ft.) boom, 1.9-m ³ (2.5 cu. yd.) bucket and 750-mm (30 in.) triple semi-grouser shoes														
7.5 m (25 ft.)												6350	6350	
6.0 m (20 ft.)									10 300	10 300	9530	7440		
									(22,410)	(22,370)	(19,670)	(15,900)		
4.5 m (15 ft.)							13 640	13 640	11 410	9960	10 080	7220		
							(29,430)	(29,430)	(24,740)	(21,430)	(21,940)	(15,490)		
3.0 m (10 ft.)					22 520	21 220	15 940	13 520	12 670	9460	10 750	6940	6160	5200
					(48,350)	(45,760)	(34,390)	(29,130)	(27,430)	(20,360)	(23,350)	(14,900)		
1.5 m (5 ft.)					18 450	18 450	17 800	12 720	13 780	9000	11 350	6680	6690	5080
					(44,110)	(42,600)	(38,470)	(27,400)	(29,820)	(19,360)	(24,380)	(14,340)		
Ground Line					18 470	18 470	18 780	12 210	14 460	8660	11 120	6470		
					(42,920)	(41,210)	(40,650)	(26,280)	(31,300)	(18,630)	(23,910)	(13,900)		
-1.5 m (-5 ft.)			11 930	11 930	23 290	19 040	18 770	11 980	14 520	8480	11 010	6370		
			(26,990)	(26,990)	(53,590)	(40,970)	(40,650)	(25,770)	(31,410)	(18,230)	(23,670)	(13,690)		
-3.0 m (-10 ft.)	14 070	14 070	18 590	18590	23 450	19 160	17 740	11 970	13 750	8460	10 530	6410		
	(31,520)	(31,520)	(42,050)	(42,050)	(50,810)	(41,140)	(38,340)	(25,760)	(29,620)	(18,200)				
-4.5 m (-15 ft.)			26 700	26 700	20 090	19 520	15 400	12 180	11 620	8640				
			(57,600)	(57,600)	(43,280)	(41,940)	(33,050)	(26,220)	(24,590)	(18,640)				
-6.0 m (-20 ft.)					14 470	14 470	10 680	10 680						
					(30,450)	(30,450)	(21,930)	(21,930)						

VISIT SITE NOW >>



HAWK

Reach Beyond, with HAWK.

VISIT SITE NOW >>

Lift Charts ZX470LC-6

Load Point Height 1.5 m (5 ft.) 3.0 m (10 ft.) 4.5 m (15 ft.) 6.0 m (20 ft.) 7.5 m (25 ft.) 9.0 m (30 ft.) 10.5 m (35 ft.)

Horizontal Distance from

Centerline of Rotation Over Front Over Side Over Front Over Side Over Front Over Side Over Front Over Side Over Front Over Side Over Front Over Side Over Front Over Side

Load Point Height	1.5 m (5 ft.)		3.0 m (10 ft.)		4.5 m (15 ft.)		6.0 m (20 ft.)		7.5 m (25 ft.)		9.0 m (30 ft.)		10.5 m (35 ft.)			
Horizontal Distance from	Over Front		Over Side		Over Front		Over Side		Over Front		Over Side		Over Front		Over Side	
With 2.9-m (9 ft. 6 in.) arm, 7.0-m (23 ft.) boom, 2.3-m³ (3.0 cu. yd.) bucket and 900-mm (36 in.) triple semi-grouser shoes																
6.0 m (20 ft.)							13 260	13 260	11 450	10 090						
							(28,560)	(28,560)	(24,910)	(21,660)						
4.5 m (15 ft.)					21 100	21 100	15 270	14 040	12 440	9720	10 830	7000				
					(44,910)	(44,910)	(32,750)	(30,070)	(26,860)	(20,800)	(23,590)	(14,970)				
3.0 m (10 ft.)							17 260	13 150	13 500	9280	11 310	6810				
							(37,080)	(28,180)	(29,090)	(19,840)	(24,520)	(14,550)				
1.5 m (5 ft.)							18 540	12 480	14 300	8910	11 350	6620				
							(39,980)	(26,790)	(30,810)	(19,010)	(24,300)	(14,130)				
Ground Line					18 040	18 040	18 810	12 150	14 570	8660	11 210	6490				
					(42,030)	(41,240)	(40,680)	(26,070)	(31,400)	(18,490)	(24,020)	(13,870)				
-1.5 m (-5 ft.)		14 410	14 410	23 410	19 250	18 100	12 090	14 110	8590							
		(32,620)	(32,620)	(51,050)	(41,460)	(39,140)	(25,910)	(30,340)	(18,340)							
-3.0 m (-10 ft.)		25 090	25 090	20 680	19 560	16 290	12 250	12 510	8710							
		(54,980)	(54,980)	(44,930)	(42,090)	(35,050)	(26,230)	(26,600)	(18,620)							
-4.5 m (-15 ft.)				16 300	16 300	12 690	12 670									
				(34,880)	(34,880)	(26,720)	(26,720)									
With 3.4-m (11 ft. 2 in.) arm, 7.0-m (23 ft.) boom, 2.1-m³ (2.7 cu. yd.) bucket and 900-mm (36 in.) triple semi-grouser shoes																
7.5 m (25 ft.)									10 340	10 340						
									(22,650)	(22,650)						
6.0 m (20 ft.)									10 990	10 390	9760	7420				
									(23,910)	(22,330)	(18,910)	(15,850)				
4.5 m (15 ft.)					19 590	19 590	14 580	14 400	12 040	9980	10 580	7260				
					(41,940)	(41,940)	(31,450)	(31,040)	(26,110)	(21,460)	(23,040)	(15,560)				
3.0 m (10 ft.)					21 700	21 010	16 770	13 520	13 220	9510	11 160	7010				
					(51,720)	(45,320)	(36,170)	(29,140)	(28,610)	(20,470)	(24,240)	(15,050)				
1.5 m (5 ft.)					13 630	13 630	18 390	12 820	14 190	9100	11 510	6780				
					(32,940)	(32,940)	(39,730)	(27,620)	(30,710)	(19,590)	(24,740)	(14,570)				
Ground Line					16 690	16 690	19 040	12 410	14 680	8820	11 330	6620				
					(38,950)	(38,950)	(41,220)	(26,720)	(31,780)	(18,980)	(24,360)	(14,220)				
-1.5 m (-5 ft.)		11 830	11 830	23 690	19 530	18 680	12 270	14 490	8690	11 270	6560					
		(26,860)	(26,860)	(53,970)	(41,920)	(40,460)	(26,390)	(31,340)	(18,700)	(24,250)	(14,120)					
-3.0 m (-10 ft.)		20 250	20 250	22 440	19 730	17 260	12 330	13 350	8730							
		(45,890)	(45,890)	(48,650)	(42,360)	(37,280)	(26,520)	(28,700)	(18,800)							
-4.5 m (-15 ft.)		23 560	23 560	18 530	18 530	14 340	12 600	10 290	9010							
		(50,800)	(50,800)	(39,860)	(39,860)	(30,650)	(27,140)									

VISIT SITE NOW >>



HAWK

Reach Beyond, with HAWK.

VISIT SITE NOW >>

Lift Charts ZX470LC-6

Boldface type indicates hydraulically limited capacity; **lightface type** indicates stability-limited capacities, in kg (lb.). All lift capacities are based on ISO 10567 (with power boost). Machine equipped with standard gauge; and situated on firm, uniform supporting surface. Total load includes weight of cables, hook, etc. Figures do not exceed 87 percent of hydraulic capacities or 75 percent of weight needed to tip machine.

Load Point Height	1.5 m (5 ft.)		3.0 m (10 ft.)		4.5 m (15 ft.)		6.0 m (20 ft.)		7.5 m (25 ft.)		9.0 m (30 ft.)		10.5 m (35 ft.)	
Horizontal Distance from Centerline of Rotation	Over Front	Over Side	Over Front	Over Side	Over Front	Over Side	Over Front	Over Side	Over Front	Over Side	Over Front	Over Side	Over Front	Over Side
With 3.9-m (12 ft. 10 in.) arm, 7.0-m (23 ft.) boom, 1.9-m ³ (2.5 cu. yd.) bucket and 900-mm (36 in.) triple semi-grouser shoes														
7.5 m (25 ft.)												6350	6350	
6.0 m (20 ft.)									10 300	10 300	9530	7540		
									(22,410)	(22,410)	(19,670)	(16,130)		
4.5 m (15 ft.)							13 640	13 640	11 410	10 090	10 080	7330		
							(29,430)	(29,430)	(24,740)	(21,710)	(21,940)	(15,710)		
3.0 m (10 ft.)					22 520	21 480	15 940	13 690	12 670	9590	10 750	7050	6160	5290
					(48,350)	(46,330)	(34,390)	(29,510)	(27,430)	(20,640)	(23,350)	(15,130)		
1.5 m (5 ft.)					18 450	18 450	17 800	12 900	13 780	9130	11 360	6780	6690	5170
					(44,110)	(43,160)	(38,470)	(27,780)	(29,820)	(19,650)	(24,640)	(14,560)		
Ground Line					18 470	18 470	18 780	12 390	14 460	8790	11 300	6580		
					(42,920)	(41,770)	(40,650)	(26,660)	(31,300)	(18,910)	(24,280)	(14,130)		
-1.5 m (-5 ft.)			11 930	11 930	23 290	19 300	18 770	12 150	14 520	8610	11 180	6470		
			(26,990)	(26,990)	(53,590)	(41,430)	(40,650)	(26,140)	(31,410)	(18,510)	(24,040)	(13,910)		
-3.0 m (-10 ft.)	14 070	14 070	18 590	18 590	23 450	19 420	17 740	12 150	13 750	8590	10 530	6510		
	(31,520)	(31,520)	(42,050)	(42,050)	(50,810)	(41,700)	(38,340)	(26,130)	(29,620)	(18,480)				
-4.5 m (-15 ft.)			26 700	26 700	20 090	19 780	15 400	12 350	11 620	8770				
			(57,600)	(57,600)	(43,280)	(42,510)	(33,050)	(26,600)	(24,590)	(18,920)				
-4.5 m (-15 ft.)			14 470	14 470	10 680	10 680								
			(30,450)	(30,450)	(21,930)	(21,930)								
With 4.9-m (16 ft. 1 in.) arm, 7.0-m (23 ft.) boom, 1.4-m ³ (1.8 cu. yd.) bucket and 900-mm (36 in.) triple semi-grouser shoes														
4.5 m (15 ft.)									10 670	10 670	9690	8140		
									(23,180)	(23,180)				
3.0 m (10 ft.)					19 780	19 780	14 760	14 760	12 130	10 500	10 540	7820		
					(42,530)	(42,530)	(31,890)	(31,890)	(26,310)	(22,610)	(22,920)	(16,820)		
1.5 m (5 ft.)					24 060	21 610	17 130	13 950	13 530	9970	11 380	7500	9570	5820
					(51,890)	(46,540)	(37,040)	(30,080)	(29,330)	(21,470)	(24,710)	(16,140)		
Ground Line			7330	7330	21 020	20 500	18 790	13 260	14 610	9530	11 960	7230	9400	5660
			(16,700)	(16,700)	(48,940)	(44,090)	(40,670)	(28,560)	(31,660)	(20,530)	(25,730)	(15,560)		
-1.5 m (-5 ft.)	6910	6910	10 850	10 850	22 090	20 000	19 510	12 850	15 160	9240	11 760	7040	9300	5570
	(15,440)	(15,440)	(24,550)	(24,550)	(50,830)	(42,970)	(42,260)	(27,660)	(32,830)	(19,900)	(25,290)	(15,160)		
-3.0 m (-10 ft.)	11 090	11 090	15 440	15 440	25 950	19 880	19 250	12 680	15 020	9100	11 670	6960		
	(24,840)	(24,840)	(34,920)	(34,920)	(56,210)	(42,710)	(41,670)	(27,290)	(32,470)	(19,610)	(25,120)	(15,000)		
-4.5 m (-15 ft.)	15 890	15 890	21 400	21 400	23 700	20 030	17 910	12 720	13 950	9130	10 790	7030		
	(35,710)	(35,710)	(48,560)	(48,560)	(51,190)	(43,060)	(38,620)	(27,390)	(29,990)	(19,680)	(22,850)	(15,180)		
-6.0 m (-20 ft.)			27 000	27 000	19 750	19 750	15 050	12 970	11 290	9360				
			(57,750)	(57,750)	(42,260)	(42,260)	(32,060)	(27,990)	(23,630)	(20,240)				
With 2.9-m (9 ft. 6 in.) ME-arm, 6.3-m (20 ft. 8 in.) ME-boom, 2.5-m ³ (3.3 cu. yd.) bucket and 900-mm (36 in.) triple semi-grouser shoes														
7.5 m (25 ft.)									12 480	12 480				
									(27,350)	(27,350)				
6.0 m (20 ft.)									13 440	13 440	12 060	10 060		
									(29,190)	(29,190)	(24,660)	(21,530)		
4.5 m (15 ft.)					19 860	19 860	15 220	14 420	12 810	9820				
					(42,650)	(42,650)	(32,910)	(31,040)	(27,860)	(21,080)				
3.0 m (10 ft.)					24 020	21 400	17 200	13 630	13 780	9460				
					(51,680)	(46,170)	(37,160)	(29,350)	(29,880)	(20,340)				
1.5 m (5 ft.)					26 230	20 130	18 660	12 950	14 550	9120				
					(56,710)	(43,340)	(40,370)	(27,890)	(31,510)	(19,600)				
Ground Line					26 140	19 690	19 120	12 560	14 750	8890				
					(56,720)	(42,310)	(41,420)	(27,020)	(31,910)	(19,120)				
-1.5 m (-5 ft.)			22 400	22 400	24 450	19 720	18 360	12 450	13 960	8840				
			(50,640)	(50,640)	(53,060)	(42,360)	(39,720)	(26,790)	(30,010)	(19,020)				
-3.0 m (-10 ft.)			27 190	27 190	21 060	20 070	15 940	12 630						
			(59,020)	(59,020)	(45,540)	(43,130)	(34,230)	(27,190)						

VISIT SITE NOW >>



HAWK

Reach Beyond, with HAWK.

VISIT SITE NOW >>

Buckets ZX470LC-6

A full line of buckets is offered to meet a wide variety of applications. Digging forces are with power boost. Buckets are equipped with ESCO teeth standard. Replaceable cutting edges and a variety of teeth are available through Hitachi parts. Optional side cutters add 150 mm (6 in.) to bucket widths. Capacities are SAE heaped ratings.

Type Bucket	Bucket Width		Bucket Capacity		Bucket Weight	
	mm	in.	m ³	cu. yd.	kg	lb.
General Purpose	1372	54	1.76	2.3	1006	2,217
	1067	42	1.41	1.8	1418	3,127
	1219	48	1.64	2.1	1507	3,323
	1372	54	1.87	2.4	1624	3,581
	1524	60	2.09	2.7	1712	3,774
Heavy-Duty	1676	66	2.30	3.0	1737	3,828
	1829	72	2.52	3.3	1844	4,065
	1829	72	3.20	4.2	1970	4,344
	1219	48	2.06	2.7	1802	3,973
	1372	54	2.34	3.1	2033	4,482
Truck Loading	1524	60	2.62	3.4	2329	5,136
	1676	66	2.91	3.8	2271	5,007
	1829	72	3.20	4.2	2663	5,870
	1219	48	2.06	2.7	1802	3,973
	1372	54	2.34	3.1	2033	4,482

Bucket Selection Guide*

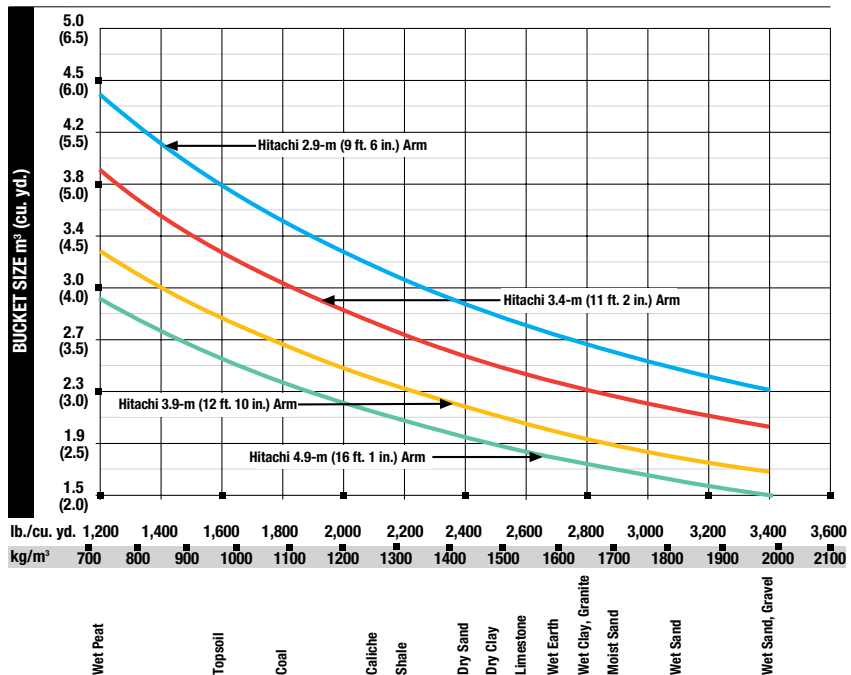

* Contact your Hitachi dealer for optimum bucket and attachment selections. These recommendations are for general conditions and average use. Does not include optional equipment such as thumbs or couplers. Larger buckets may be possible when using light materials, for flat and level operations, less compacted materials, and volume loading applications such as mass-excavation applications in ideal conditions. Smaller buckets are recommended for adverse conditions such as off-level applications, rocks, and uneven surfaces. Bucket capacity indicated is SAE heaped.

VISIT SITE NOW >>



ADDITIONAL EQUIPMENT

Key: ● Standard ▲ Optional or special kit

470 Engine

- Auto-idle system
- Batteries (2 - 12 volt)
- Coolant recovery tank
- Dual-element dry-type air filter
- Electronic engine control
- Enclosed fan guard (conforms to SAE J1308)
- Engine coolant to -37 deg. C (-34 deg. F)
- Automatic belt-tension device
- Fuel filter with water separator
- Full-flow oil filter
- Turbocharger with charge air cooler
- Cool-on-demand hydraulic-driven fan
- 500-hour engine-oil-change interval
- 70% (35 deg.) off-level capability
- Hydraulic fan reverser

Hydraulic System

- Reduced-drift valve for boom down, arm in
- Auxiliary hydraulic valve section
- Spring-applied, hydraulically released automatic swing brake
- Auxiliary hydraulic-flow adjustments through monitor
- Auto power lift
- 4,000-hour hydraulic-oil-change interval
- ▲ Auxiliary hydraulic lines
- ▲ Auxiliary pilot and electric controls
- ▲ Hydraulic-filter-restriction indicator kit
- ▲ Single-pedal propel control
- ▲ Control pattern change valve

Undercarriage

- Planetary drive with axial piston motors
- Propel motor shields
- Spring-applied, hydraulically released automatic propel brake
- Track guides, front idler and center
- 2-speed propel with automatic shift
- Upper carrier rollers (3)
- Sealed and lubricated track chain
- ▲ Triple semi-grouser shoes, 750 mm (30 in.)
- ▲ Triple semi-grouser shoes, 900 mm (36 in.)

470 Upperstructure

- Right-hand, left-hand mirrors
- Vandal locks with ignition key: Cab door / Fuel cap / Service doors / Toolbox
- Debris screen in side panel
- Remote-mounted engine oil and fuel filters
- Service platform, left side
- Service handrails
- ▲ Counterweight-removal system

Front Attachments

- Centralized lubrication system
- Dirt seals on all bucket pins
- No-boom-arm option
- ▲ Boom, 7 m (23 ft.)
- ▲ Boom, mass excavating, 6.3 m (20 ft. 7 in.)
- ▲ Arm, mass excavating, 2.9 m (9 ft. 6 in.)
- ▲ Arm, 3.4 m (11 ft. 2 in.)
- ▲ Arm, 3.9 m (12 ft. 10 in.)
- ▲ Arm, 4.9 m (16 ft. 1 in.)
- ▲ Buckets: Heavy duty / Heavy-duty high capacity / Side cutters and teeth

Operator's Station

- Adjustable independent-control positions (levers-to-seat, seat-to-pedals)
- AM/FM radio
- Auto climate control / air conditioner / heater / pressurizer
- Cell-phone power outlet, 12 volt, 60 watt, 5 amp
- Coat hook
- Deluxe-suspension cloth seat with 100-mm (4 in.) adjustable armrests
- Floor mat
- Front windshield wiper with intermittent speeds
- Gauges (illuminated): Diesel Exhaust Fluid (DEF) / Engine coolant / Fuel
- Horn, electric
- Hour meter, electric
- Hydraulic shutoff lever, all controls
- Hydraulic warm-up control
- Interior light
- Large cup holder
- Machine Information Center (MIC)

470 Operator's Station (continued)

- Mode selectors (illuminated): Power modes (3) / Travel modes (2 with automatic shift) / Work mode (1)
- Multifunction, color LCD monitor with: Diagnostic capability / Multiple-language capabilities / Maintenance tracking / Clock / System monitoring with alarm features: Auto-idle indicator, engine-air-cleaner-restriction indicator light, engine check, engine-coolant-temperature indicator light with audible alarm, engine-oil-pressure indicator light with audible alarm, low-alternator-charge indicator light, low-fuel indicator light, low DEF indication with audible alarm, fault-code-alert indicator, fuel-rate display, wiper-mode indicator, work-lights-on indicator and work-mode indicator
- Motion alarm with cancel switch (conforms to SAE J994)
- Power-boost switch on right console lever
- Propel pedals and levers
- SAE 2-lever control pattern
- Seat belt, 51 mm (2 in.), retractable
- Tinted glass
- Transparent tinted overhead hatch
- Hot/cold beverage compartment
- ▲ Protection screens for cab front
- ▲ Seat belt, 76 mm (3 in.), non-retractable
- ▲ Window vandal-protection covers

Electrical

- 100-amp alternator
- Blade-type multi-fused circuits
- Positive-terminal battery covers
- Battery disconnect switch
- ZXLink™ wireless communication system (available in specific countries; see your dealer for details)

▲ Cab extension wiring harness

Lights

- Work lights: Halogen / 2 mounted on boom / 1 mounted on frame / 2 mounted on top of cab

See your Hitachi dealer for further information.

Net engine power is with standard equipment including air cleaner, exhaust system, alternator and cooling fan, at test conditions specified per ISO 9249. No derating is required up to 2000-m (6,560 ft.) altitude. Specifications and design subject to change without notice. Wherever applicable, specifications are in accordance with SAE standards. Except where otherwise noted, these specifications are based on a unit with 1370-mm (54 in.) bucket, 900-mm (36 in.) triple semi-grouser shoes, 8400-kg (18,519 lb.) counterweight with removal device, full fuel tank and 79-kg (175 lb.) operator.